

**KÖBER S.R.L. Turturești
Vaduri Branch Office**



WALL HUNG GAS BOILERS



TECHNICAL INSTRUCTIONS FOR INSTALLATION/ USAGE/ MAINTENANCE



**OPTIMUS MT
C15SPV 24MEFM**

ISCIR CERT*
CE 1798

KÖBER LTD TURTURESTI VADURI BRANCH OFFICE

Branch Office :Vaduri, No. 280, Alexandru cel Bun, Neamț District, Postal Code 617511, Romania

Phone : +40.233.24.17.46, 233.24.19.33, Fax : +40.233.24.19.29

E-mail : office.vaduri@kober.ro, www.motan.ro

INTRODUCTION TO THE BOILER

General description of the boiler

The wall hung gas boiler is a fuel gas-consuming appliance which has the role of turning the fuel gas power into thermal energy through burning.

This appliance runs unsupervised due to its protection and control systems.

The boiler is made of many parts that we are going to describe in the following chapters.

The gas enters inside the boiler through the gas feeding circuit made of a coupling and a reducing valve which will be set at 20 mbar for G20 A(L) and A(H) subgroups. The reducing valve will be set at 37 mbar for LPG (propane subgroups and propane-butane mixtures). Thus it gets into the gas valve which has the role of controlling the gas discharge at the outlet to the burner.

The ignition achieves by flame activating by an ignition electrode, by means of an ignition transformer.

During the combustion, the flame sensing is made by an ionization sensor.

The boiler type with forced draft is provided with a fan which evacuates the exhaust gases. In the initiation phase, this evacuates an air volume to provide an unexplosive ignition. The explosive ignition may occur due to a gas storage from the non-operating period.

The combustion chamber, as a plate parallelotope, interior ceramics fibre-lined, is designed to allow the transfer to the exchanger with less heat leakages.

In case of the CH circuit of the two heat exchangers type, the heat resulted from fuel gas ignition is taken over by the monothermal heat exchanger and sent to the thermal agent (water) which is delivered by the circulating pump through the heating installation. In case of on the DHW circuit, a water discharge is detected by the flowmeter, the 3- way gas valve is energized. The 3- way gas valve achieves the transition from the central heating circuit on the short circuit through the plate heat exchanger (the main plate heat exchanger) and the heat transfer is realized by means of this to the DHW circuit (the secondary plate heat exchanger).

The scavenging is realized by means of the fan.

The running protection and control are performed electronically. The boiler setting is made from the control board (see the chapter concerning this subject).

DESCRIPTION OF THE BOILER

BOILER TYPE	Useful power	Accessories			DHW instant production
	[kcal/h]	The fan	The pump	The expansion vessel	
OPTIMUS MT C15 SPV 24 MEFM	20670	X	X	X	X

SYMBOLS

S- with instant production of DHW (without cumulation)

P- with pump

V-with closed expansion vessel

24-the maximum power output in kW

M- the burner is supplied by a continuous modulating valve

E- the ignition and the control of the flame are electronically-made





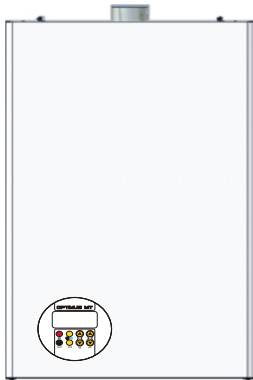







F-the forced scavenging

M-monothermal



OPTIMUS MT C 15 SPV 24 MEFM

GENERAL INSTRUCTIONS CONCERNING THE BOILER SAFETY

-  This manual is part of the product and it has to be given to the user.
-  Read this manual carefully and keep it carefully for a further application by the user and by the mounting and installing authorized personnel.
-  The installation, the putting into service, the service-repair operations and a periodical technical checking are performed only by the ISCIR authorized personnel in accordance with the current standards (P.S.I., NTSM) as the A.N.R.G.N. and C.O.N.E.L. standards. All the indications of this manual must be respected; any exception may cause damages and the producer isn't responsible for these.
-  In case of a defective running of the device, shut it down and call up immediately one of the breakdown services units on the attached phone numbers or the producer on the phone numbers :0233/ 241746; 241933.
-  To guarantee the boiler efficiency and its correct running it is recommendable that the boiler be checked yearly by the qualified personnel, complying with the manufacturer's conditions.
-  If the device is sold or given, make sure it is delivered with its technical handbook in order to be consulted by the new user/ installer.
-  In case of some components damaging there will be used only the original components. You must have the manufacturer's acceptance to use some components from another company, you must obtain the written acceptance of the producer so that you may use those components.
-  This boiler will be used properly. Any other use will be considered unsuitable.
-  There is excluded any contractual or extra-contractual responsibility of the producer for the damages caused by the installing or usage errors and by the non-observance of his instructions.
-  The maximum limit of the water hardness inlet is of maximum 5°F (French degrees) on the DHW circuit, equal to 50 mg CaCO₂ or an equivalent quantity of other salts as Ca and Mg. It is compulsory to install a softener filter on the domestic water circuit, a mechanical impurities filter (Y filter) on the CH installation return and a pressure controller on the gas supply circuit.
-  It is recommendable to use these boilers types presented in this manual to heat areas of 150 mp (at a medium height of 2,5 m of the heat volume).
-  Unsubmitting to these technical manual regulations as to the warranty certificate leads to warranty loss.

CARACTERISTICI TEHNICE**CONSTRUCTIVE AND FUNCTIONAL CHARACTERISTICS**

Name	OPTIMUS MT
Type	OPTIMUS MT - C 15 SPV 24 MEFM
Draft	Forced
Combustion chamber	Sealed
Efficiency at maximum load	92,7%
Efficiency at minimum load	93,7%
Useful power (min/ max)	10 - 23,7 kw
Burner nominal load (min/ max)	10,9 - 25,49 kw
Gas pressure NG on coupling (behind the reducer) NG on maximum admitted output LPG	20 mbar 35 mbar 30 - 37 mbar
Power-supply	230 VAC, 50 Hz
Power consumption	160 W
Weight	40 kg
Heat exchanger output	1 L
NG consumption (8500 kcal/ Nm ³) At useful power (max/ min)	1,1- 2,6 Nm ³ /h
LPG consumption (20425 kcal/ kg) At maximum output	0,4 - 1,07 kg/h
Central heating	-
Minimum and maximum admitted pressure	0,5 și 3 bar
Temperature on the heating circuit	40 - 80°C
Connections - inlet outlet central heating - inlet outlet DHW - gas supply	3/4" 1/2" 3/4"
Dimensions - depth (mm) - Width (mm) - Height (mm) - With mounted elbow (mm)	275 415 700 850
Expansion vessel with membrane	7 L
DHW temperature range	30 - 60°C
Flow values Δt=25°C Δt=35°C Δt=45°C	13,5 l/min 9,7 l/min 7,5l/min

Domestic cold water pressure	0,2 - 8 bar
Exhaust gases temperature at rated output	142,4°C
Burned gases connection (input- output)	Ø 100 / Ø 60
Burned gases connection length	Max 3 m
Orientative values Maximum water content in the installation Maximum surface of the precinct	150 l 150 m ²

PRINCIPAL COMPONENTS OF THE BOILER

The heat generator

It is designed to supply the necessary heat for the heating exchange with the heating and DHW circuits. It is made of the following elements:

The gas feeding circuit will be performed through a reducing valve which will set the inlet pressure at 20-25 mbar NG, respectively 30-37 mbar for LPG.



It is compulsory to mount a pressure controller on the gas feeding circuit.

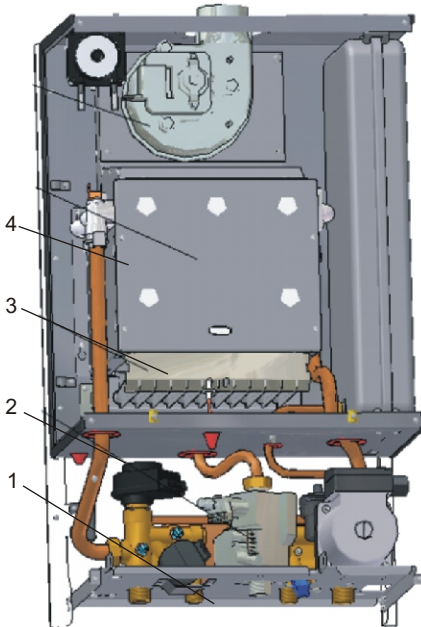

1. The gas valve is designed to allow a continuous modulation of combustion, supplying the minimum, medium and maximum gas pressures required by the boiler running at the minimum, medium and maximum load. The connector between the gas valve and the burner is the copper pipe (14x1).

2. The burner is stainless-made, forced or atmospheric, with 11 canular inclines and it runs with fuel gas (NG or LPG). The burner output is set in a modulated system by means of a gas modulating valve so that it supply a maximum useful power of 23,7 kW.

3. The combustion chamber is design to allow the heat transfer to the heat exchanger with less heat leakages. We chose a simple constructive solution as a rectangular piping of 170 mm between the burner and the heat exchanger. To reduce the heat leakages, the piping walls are isolated indoor with heat insulating material (ceramics fibres).

4 The fan

The boiler is provided with a fan for scavenging.

- The flue system and the air supply (for the boiler with forced draft) is made of two concentric pipes connected to the outside of the room where the boiler is mounted.

The exhaust gases/ water heat exchanger

The exhaust gases/ water heat exchanger is monothermal, the domestic water is heated through the plate heat exchanger.

From the power point of view the rated output is of 24 kW and the efficiency over 93%.

The heating and DHW circuits - Hydraulic circuits

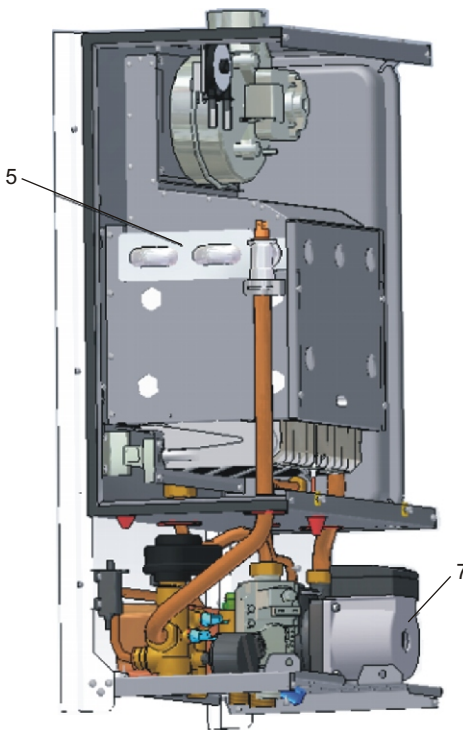

They are designed to allow the thermal transfer to the external heating and DHW installations.

The heating circuit

- the loading circuit of the installation is made of the valve and the copper pipe connected to the domestic cold water supply line;
- the relief valve of the circuit is designed to reduce the pressure from the heating circuit and to open at 3 bars full pressure;
- the ventilation circuit of the installation is made of an air-release valve which allows the air discharge from the heating circuit, mounted on the circulating pump shell;
- The heating agent recirculating pump (7) is designed to supply the output necessary for the heating agent recycling through the heating circuit;
- Expansion vessel is designed to allow the expansion processes from the heat installation, preventing from hydraulics overstraining or damaging. This has a capacity of 7 litres.
- The automatic by-pass circuit is made of a copper pipe of 14x1 mm fixed between the heating circuit turn and return and a safety valve set to open at 0,3 bar to allow the heat carrier recycling through the heat exchanger and pump, in case of some pressure differences, between the external heat installation turn and return at over 0,3 bar.

- DHW circuit is with plate heat exchanger.

The command and control system of the boiler running performs:

- the ignition and the protection when the flame is extinguished, provided by the electronic ignition;
- the protection when the gas is switched off, provided by electro-valve;
- the water pressure signalling in the boiler, provided by minimum pressure sensor;
- the temperature signalling on the heating and DHW circuits, provided by the electronic board functions;
- the setting of the heating cycle following the instructions of the temperature control switch;
- the safety of the boiler against excessive temperature, provided by the safety thermostat at overpressure, through the safety valve and at water leakages through the minimum pressure switch from the circuit;
- protection against draft deficiency, by the fan derangement or the exhaust piping blockage of the exhaust gases, provided by the combustion pressure switch.

The command and control system is made of the following components:

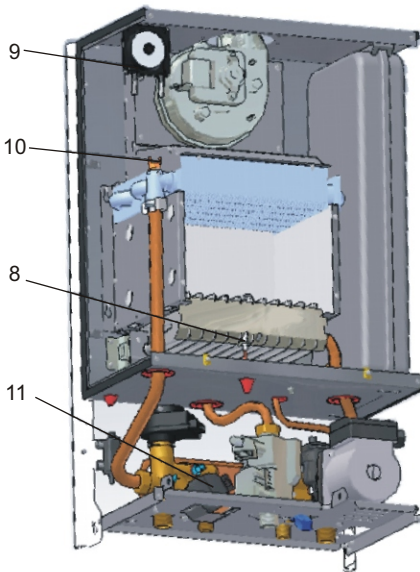

- **the electronic board** as a controller of the boiler running (see the attached drawing).
- the measuring and pilot cells of the functional parameters for the boiler

- **heating circuit temperature sensor** which sends the temperature signal to the electronic control block of the heating circuit.

- **DHW temperature sensor** which sends the temperature signal to the electronic control block of the DHW circuit.

- **Flowmeter** as a detector of the DHW consumption which sends the DHW circuit running command to the electronic control block.

- **Ignition/ ionization electrode (8)** with double role, of combustion flame activation and sensing.

- **Air pressure switch (9)** as a detector and controller of the exhaust gases, which determines the heating and DHW circuits running.

- **Temperature sensors** as reading the temperature on the heating circuit (the electronic board display).

- **Temperature switch (10)** as a detector and controller of the maximum temperature on the heating circuit which sends the non-running command of the heating circuit in case a maximum admitted temperature is exceeded.

- **Programmer ambient sensor** as setting the ambient temperature from a room (optional).

- **Water pressure sensor** as a detector of the minimum pressure on the heating circuit.

The external shell

It has a parallelepipedal shape. It is detachable and electrostatically painted. The shell covers the pressurized combustion chamber and the enclosed installations.

For designing the central heating installation we must be aware of the hydraulic features of the pump.

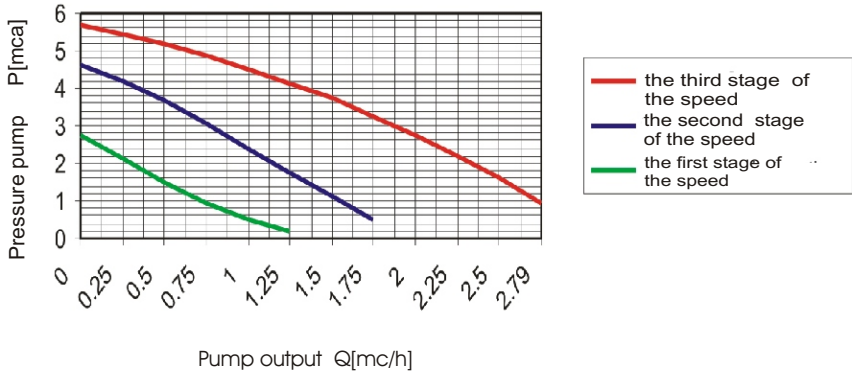

The hydraulic characteristic of the pump



MOUNTIG-INSTALLATION INSTRUCTIONS

The chapter addresses both to the qualified persons which contribute to the boiler installation and to the beneficiary which is concerned that the effected works to be done following the safety rules in operation of all the installations which contribute to the good running of the



-  The boiler installation is not the same with the boiler starting.
-  The boiler starting must be done by the qualified and certified personnel by KOBET LTD Turturesti Vaduri Branch Office and authorized in accordance with the current legislation.
-  There is no guarantee without the authorized personnel signing the putting into service statement, and the company withdraws any boiler guarantee or running responsibilities.

The boiler location

In accordance with the current regulations: The norms for the designing and execution of the NG supply systems, The norms for the NG supply systems utilization 16/98 chapter 8 and I31 The norms for the designing and execution of the liquefied petroleum gas supply systems (LPG).

There are several conditions for installing the boilers:

-The appliances have the protection IP 40 level in accordance with the Testing Report no.22/29.03.2004.

-The boiler may be installed in any room with an air humidity of maximum 60% between 20-30° C, according to the Testing Report no.22/29.03.2004.

The central heating

The heating system will be designed by the qualified personnel and authorized according to PT A1-2002, in the mounting/installing activities, submitting the standards I 13 Standard for the designing and execution the heating systems and which execute these works, so that the installation could be used in best conditions.

It is important to pay attention to the pipes dimensions, head losses and heating elements while designing the heating system.

The installation filling up must be done with softened water.

Couplings and sockets

Couplings may be executed by gluing or compression fittings for the copper pipes, coupling etc. The pipes must be provided with the necessary inclination for the ventilation and a light evacuation to the adequate points from the installation.

The evacuation. The evacuation points must be situated in the practicable places which allow the water drainage from the heating circuit. It is recommendable that the minimum diameter should be ½.

The ventilation. It is recommendable that the manual ventilators should be introduced on each heating element (central heating). The water contains a certain quantity of resolved gases at the first filling as well as the further water fillings of the heating system.

Once the system has been heated, the gases will be collected in the highest points of the system whence they must discharged. The installation of some (manual or automatic) ventilators will allow the evacuation both at the first filling and during the running, in these system points.

The filling. After the pipes connecting, the two circuits will be filled up with water gradually (the boiler and the installation, respectively the coil from the DHW circuit) till the complete filling and it should be checked so that there are no leakages.

MOUNTING-INSTALLATION INSTRUCTIONS



 **You must not use the boiler empty or only partly filled with water.**

 **THE USE OF EMPTY OR PARTLY FILLED BOILER MAY LEADS TO EXPLOSION.**

 **The domestic cold water supply pipe of the DHW processing circuit remains permanently open (the closing of the net is made only by the valves from the discharge points) to allow the dilatation taking over from this circuit.**

The gas supply

The gas supply (NG or LPG) must be done in accordance with the standards (I6-98).

* The minimum/maximum inlet pressure in the gas valve, in case of using the natural gas must be between 25-30mbar static and between 20-25 mbar dynamic.

* The minimum/maximum inlet pressure in the gas valve, in case of using LPG, must be between 30-50 mbar static and 25-45 mbar dynamic.

In case of not subsuming to these standards the combustion performances will lower.

On installing you must know the gas type that the boiler has been set for, to reset it correctly for another gas type if it needs.

For exchanging the NG running for the LPG running you must follow two operations:

* The setting from the electronic board which is performed by positioning the J6 jumper (see the Electrical Diagram from ADDITIONAL INFORMATION) on the two pines LPG module. (The J6 jumper is situated on a single pine methane gas module).

* The mounting of the nozzles set of 0,77 mm diameter used for LPG running. (The diameter of these nozzles is 1,3 mm for methane gas).

The exchanging for NG is realized by performing the setting operations, from above, in the reverse sense.

The setting will be performed by the producer following the beneficiary request or the service authorized according to the current standards, operation which is performed on putting into service.



 **You must install a pressure controller on the gas supply circuit.**



 **The gas supply pipes must not have diameters smaller than the boiler coupling.**

Electric power supply

The boiler must be connected to a monophasic net of 220 V-50 Hz with zero protection, through the 5A fusible plugs. The colours semantics will be as follow: brown= phase, blue=null, green-yellow= earthing.

The external connections must be according to the current standards. The connection to the electrical network of the building must allow a complete electrical isolation of the boiler in case an intervention must be done.



It's forbidden to install the boiler without earthing.

THE COUPLING FOR SCAVENGING

Without coupling to the chimney

The scavenging is made through a pipe of 60 mm diameter, coaxial with the air inlet pipe of 100 mm diameter. The exhaust pipe is within the inlet one.

The input-output coaxial flue system is delivered with the boiler. It is made of an elbow, input-output pipe and the necessary fittings.



 **You must not shut down the exhaust checking device, because your life and health will be in danger.**

 **Only the qualified personnel will do the replacement, according to the current legislation and to the original pieces used by the producer.**



 **It is obligatory to place the boilers in areas with ventilation according to the current standards. The technical instructions should be studied before mounting/ installing, starting or servicing.**

INSTRUCTIONS FOR THE FINAL USER (BENEFECIARY)

The control, protection and automation elements provide:

- * The flame ignition
- * The flame sensing
- * The temperature and water signalling in the boiler
- * The temperature regulation on the heating circuit
- * The temperature regulation on the DHW circuit
- * The pump starting at the heating water demand
- * The safety of the boiler at overheating and overpressure
- * Draft deficiency (air pressure switch)
- * The boiler safety at minimum water level (water pressure switch)
- * The DHW demand sensing (flowmeter) and giving priority to this discharge

The indicators and the operating buttons are placed on the control board.
The chronothermostat or the room thermostat may be installed on demand.

UTILIZATION INSTRUCTIONS

The control board

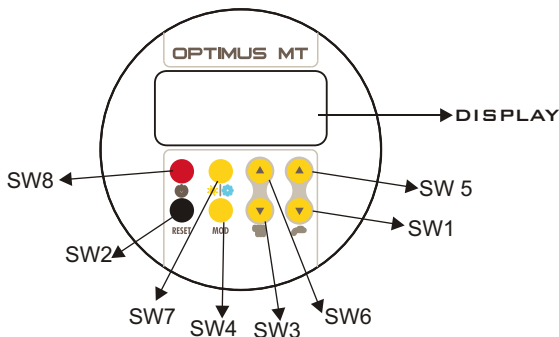

Fig 1. The control board for OPTIMUS MT

Display board LCD in the user module

Button - Operation function

- SW8** On/Off: This button shuts down/ opens out the boiler (the boiler is still connected to the tension). In the module Off the board is deactivated completely excepting the symbol 1. When activating, the activated symbols appear on the LCD display while the symbol 1 disappears
- SW 7** Summer/ winter: Pressing this button, you select summer or winter module. The activated symbols are two for the summer (in this module, any value of the temperature is displayed in stand-by, while, if there is any DHW demand, the DHW setting temperature will appear) and 3 for the winter module.
- SW2** Reset from blocking: reset if the boiler is in Err E2, otherwise there will be no result.

- SW 4** Comfort: pressing this button, you select the comfort module(symbol 6 on) and the set range of the domestic circuit may decrease. Press again to cancel it (symbol 6 off).
- SW3** (-) Heating: Pressing the button once, the temperature preset by the heating is displayed; the setting will decrease if you keep pressing. While visualizing the set point by the heating, the symbol 8 is flickering. If the external probe is activated, the temperature of the core circuit will not be changed directly, but two different parameters will decrease: the wanted temperature into the room and after 5 seconds the symbol "-" will appear on the display and it holds for one second, then the dispersion coefficient into the building is displayed and may be changed.
- SW6** (+) Heating: Pressing the button once, the temperature preset by the heating is displayed; the setting increases if you keep pressing. While visualizing the set point by the heating, the symbol 8 is flickering. The heating, the temperature from the room and the dispersion coefficient may be increased in the same way as SW3.
- SW1** (-) DHW: Pressing the button once, the preset temperature of the DHW is displayed; if you keep pressing the setting will decrease. While visualizing the set point by the heating, the symbol 7 is flickering.
- SW5** (+) DHW: Pressing the button once, the preset temperature of the DHW is displayed; if you keep pressing the setting will decrease. While visualizing the set point by the heating, the symbol 7 is flickering.
- SW7+SW8** Chimney sweep" function: If you press SW7 and SW8 simultaneously, With the boiler in Off position, you will activate "Chimney sweep" function, the released temperature is displayed and the symbol 5 starts flickering. After the normal starting cycle of the heating it starts at maximum capacity. This situation persists till the temperature of the core circuit reaches a safety threshold, after which the heat is deactivated and it will be activated again in the moment that the temperature reduces below the limit. Any DHW demand activates this function, but it may be done manually by pressing the button SW7 and the symbol 5 will vanish.

Values range controlled by the display panel LCD

-the heating system	30-80°C
-the heating from bottom system	15-40°C
-domestic hot water	30-60°C
-DHW comfort	35-45°C
-External sensor:	
the temperature in the room	10-30°C
dispersion coefficient	5-35°C
-ignition power (soft-start)	0-99% of modulation current
-max. heating power	0-99% of modulation current
-max. fan speed	0-99% of fan speed
-min. fan speed	0-99% of fan speed

Electronic board operating

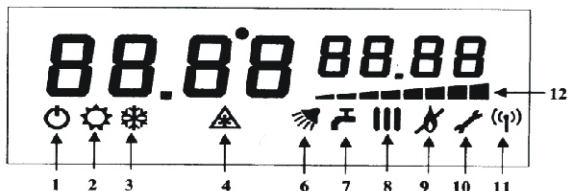

DHW module in case of monothermal boilers (symbol 7 on)

Ignition demand in the DHW module takes priority of the heating module. The burner ignition takes place when a DHW demand appears; the boiler tries to supply hot water to the user at a preset temperature. The demand is detected through the flowmeter. In this case, the pump runs. If the hot water temperature is higher than the preset value, the boiler will shut down. As soon as the heat wasted, the boiler is activated again.

The heating module (symbol 8 on)

If the boiler is on the winter programme and by deactivating the room thermostat, the domestic water temperature is lower than the one set before, the boiler will carry out the ignition at soft-start power, the flame modulation starts and keeps running till the boiler reaches the running position. If the water temperature is higher than the previous set limit, the boiler will shut down but the pump will still be active; re-ignition occurs when the water temperature decreases below the set value, on condition that a lapse of time "of preventing from appearing the frequent cycles" have passed. The maximum power of the boiler in the heating module is set by means of the buttons from the control panel during the heating.

Anti-frost function (symbol 4)

When the sensor of the system detects a temperature lower than (6°C), the burner is activated in the heating module and the pump starts running. This state persists until the cancellation temperature of the anti-frost function is reached (20°C).

"Chimney-sweep" function (symbol 5)

This function is created specially to cancel the normal adjustment of the boiler control, allowing it function at the maximum heating power. The function is useful during installation and the moment when the combustion products are verified according to the current standards. The function may be deactivated manually from the control board or at any other DHW demand.

The self-checking system and the protection function

The system is provided with several diagnostic functions, signalling the operating position of the boiler and the disturbances type which may occur on the control board display:

-the domestic water temperature:

the heating temperature in °C (from 0°C to 99°C) or the DHW system is displayed (if available)

-blocking the adequate temperature (irregularity):

in case of a failure in detecting the flame at the end of the three ignition cycles, the mother is to block and the symbol flickering ErrE2 occurs on the control panel display.

-parasite flame (irregularity)

in case of a presence of a parasite flame, the symbol Err E7 flickering occurs.

--insufficient pressure of the water in the hydraulic core circuit (irregularity):
in case the pressure sensor measures an insufficient pressure of the water in the system, (<0,5 bar) the burner and the pump are deactivated and the flickering intermittent symbol Err E1 occurs on the display.

Disturbance of a temperature sensor (irregularity):

1. Sensor for the central heating water: any disturbance of the sensor caused by a wrong contact or a short-circuit leads to the immediate deactivation of the burner, pump and the flickering intermittent symbol Err E1 occurs.
2. Sensor for DHW: any disturbance of the sensor caused by the wrong contact doesn't lead to the immediate deactivation of the burner but to displaying the flickering intermittent symbol Err E4 for monothermal boilers.

-Absence of draft on start (irregularity):

In case the pressure switch doesn't commute the TW pre-cleaning in due time, the boiler won't start running and the intermittent symbol Err E5 will occur after 10 seconds. This irregularity vanishes when the flame is detected at the end of the operating cycle.

Removing the combustion products causes the activation of the safety devices (irregularity): OPEN CHAMBER

The safety devices of the combustion products are activated and cause the boiler automatic shutting down, the intermittent symbol E5 occurs on display. This irregularity disappears only pressing the button SW3.

In case the limit thermostat (LT) is activated, the system will shut down automatically and the intermittent symbol Err E8 occurs on the control panel display. This irregularity persists even if LT is deactivated. To reset the normal operating system it is sufficient to press the reset button Sw2. The boiler shutting-down in safety conditions. In case the final user establishes that the appliance has an abnormal running, if the error codes keep displaying or if the appliance manifestations can not be understood, he has the obligation of shutting-down the boiler as soon as possible and in maximum safety conditions. The user must perform the following operations:

- * press STAND BY and the boiler shuts down
- * disconnect the boiler from the electric power supply circuit by unplugging
- * Disconnect the gas supply circuit by switching on the gas valves
- * Interrupt the DHW and the DCW circulation by switching on the gas valves

corresponding to these circuits.

After boiler shutting down in maximum safety conditions, the user will call the service unit he belongs to (see chapter 1, subchapter 1.4).

The pressure visualizing

The pressure from installation is displayed and it is useful to installation filling up. The beneficiary will check recurrently whether the pressure in installation has lowered below the value set on filling.

The pressure will maintain between 1-2 bars. If the minimum pressure lowers below the value of 0,5 bars the boiler will display the E1 signal and it will shut down. If the pressure exceeds the value of 3 bars, the safety relief valve will open and it will release the system from the accumulated pressure.

THE BOILER RUNNING

The boiler running will be < without permanent control> provided automatically by the controllers installed on the boiler, and eventually by the environment devices (room thermostat). These devices must be set at the temperature corresponding to the controlled environment.

- a. the temperature setting on the heating circuit will be between 40-80°
- b. the room thermostat will be set at the wanted temperature in the room.

In case the central heating installation is drawn off the tension during the cold period or in case, due to some disturbances, the water temperature from the boiler will be below zero degree for more than 2-3 hours, the boiler, the heating installation and the domestic water installation will be exhausted.

Also the boiler supply will be disconnected from the current and gases net. Aze.

ANOTHER FUNCTIONS CONCERNING THE BOILER SAFETY

1) The pump post-circulation

Each time the boiler is shutting down (in the heating module), the pump keeps running for a short period of time so that it could prevent from water overheating in the main heat exchanger.

2) The pump anti-blocking function

If the boiler doesn't effect any cycle during a 24 h period, the pump will start running for a few seconds to avoid blocking caused by the non-running.

3) The 3-way valve anti-blocking function

On each pump shutting down, the deflection valve is activated for one second and then it reverts to the initial position.

Additional facilities you may obtain

Mounting an exterior temperature sensor, the boiler adjusts the heat carrier temperature depending on the temperature value from outside the building, the room wanted temperature and the heat leakage coefficient through the building walls.

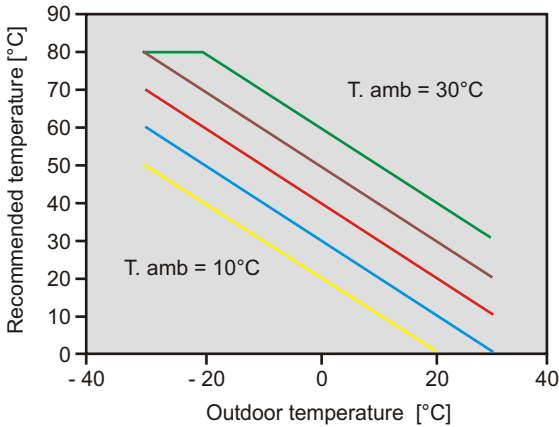

The heating circuit temperature diagram depending on the outdoor temperature at different set room temperatures and $Ke=1$

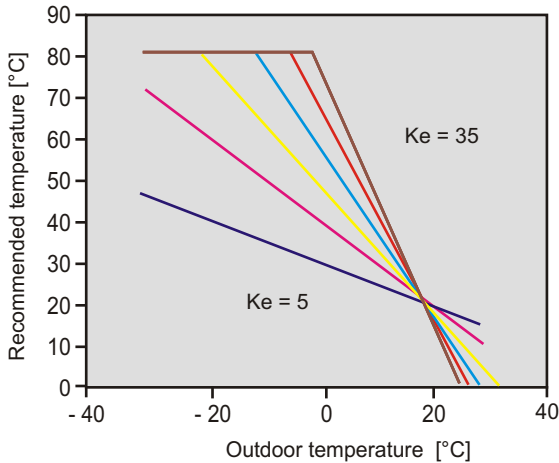

The heating circuit temperature diagram at different set room dispersion coefficients

$$\text{Heating temperature} = \text{Room temperature} + Ke * (\text{room temperature} - \text{outdoor temperature})$$

Room temperature - the temperature of the room
 Outdoor temperature - the external temperature
 Ke - dispersion coefficient

Delivering to the user

It is compulsory that the qualified personnel to instruct the user in great detail about the following aspects on boiler starting:

The boiler starting and the shutting-down procedures, in safety conditions by checking the following elements:

- * the electric power supply respecting the polarity
- * gas supply
- * the central heating circuit supply and loading
- * the filling valve must be closed
- * the pressure in installation by the manometers displaying from the control panel (1-2 bars)

- * the valves from the DHW circuit should be opened

The running mode of the boiler and the possible problems which may occur. Also, the importance of each button or switch from the control panel will be explained.

The user is warned that a water pressure falling in the system is caused by the heat carrier loss which must be rectified before using the boiler again.

It is recommended that the user should ask for a checking of the boiler running by an authorized person at least once a year.

The user is warned upon the precautions against freezing.

The instructions manual is delivered to the user.

At the end of the instruction they must sign a document of putting into service, as he assimilated the proper mode of the boiler utilization. This document is signed by the authorized person too who performs the putting into service, who trained.

The person who performs the starting has the right of refusing the putting into service of the boiler if he establishes that there are some irregularities, and he won't contract the document till these irregularities are remedied.

The one who performs the putting into service has not the obligation of rectifying the mounting errors but he assumes the responsibility that the installations correspond to the chosen boiler from the functional and constructive point of view.

RECOMMENDATIONS FOR YEARLY CHECKING







It is compulsory to check the boiler at a least two years period, according to Order 397 from 02.08.2002 related to approval of the technical indication PTA1-2002.

For a good running of the boiler and prolonging the boiler life it is necessary to be checked by an authorized person at least once time a year. It is recommendable that this checking to be done before the cold period, when the boiler won't be used at the maximum capacity. The following operations will be performed as: the main burner running is controlled and the burner is cleaned in case this thing is compulsory; the boiler exhaust flue is checked and cleaned; the gas valve controls are verified; the pump is verified; the scavenging system running is verified; the air pressure switch running and the flue system tightness are verified; the combustion correctness is checked, by analysing the exhaust gases; the gas supply system tightness is verified, the district heating and the DHW circuits tightness are checked, the electrical installation is verified..

STAMPING, DOCUMENTS, PACKING, STORAGE, QUALITY AND GUARANTEE CONDITIONS

STAMPING

A designated card is fixed on each product by sticking with following:

-  The manufacturer company
-  The name of the product
-  The serial number and the lot
-  The number of CE type examination certificate
-  Quality Department authority sign
-  The boiler type and size
- The gas type which the input rated pressure has been set for

DOCUMENTS

Each boiler is delivered with:

Technical manual, quality and guarantee certificates, conformity assignment, CE certificate issued by ISCIR CERT (copy), the putting into service and the maintenance Cards, The additional components list, Appliance book (annex D at P.T.A1.)

PACKING

The boilers will be packed into the cardboard boxes, protected by boxboard angles.

The boiler will be delivered with all the installed components, less those from the Appliance book.

STORAGE

The boilers storage is achieved in dry places and protected by the bad weather and the chemical agents.

SHIPMENT

During the shipment all the necessary measures must be taken to avoid the strokes or the boiler damaging.

QUALITY AND GUARANTEE CONDITIONS:

KOBER LTD TURTURESTI VADURI BRANCH OFFICE, as manufacturer, guarantees the boiler good running for a two years period from the moment of putting into service.

The guarantee is given if the following conditions are provided:

- * The correct installation and setting by the authorized personnel.
- * The yearly examinations are achieved on beneficiary demand and at the expense of the beneficiary, the first year examination is compulsory to maintain the guarantee for the first two years of usage.
- * The exchanged components will be warranted for one year. This doesn't mean that the set guarantee period will prolong for the entire device.
- * The guarantee period prolongs from the moment the user has claimed the device breakdown and till the time the device will be putted into service again.
- * The heating installation designing and execution should be performed by qualified person and a qualified unity (if need be).
- * It is necessary to check and clean the installation before mounting the boiler in case of an existing installations.
- * The interventions during the warranty period will be performed only by the authorized personnel of the manufacturer company.
- * Any repair by another person except the authorized personnel of the manufacturer company leads to warranty loss.

RESPONSIBILITIES DURING THE WARRANTY PERIOD

OPTIMUS MT Boiler C 15 SPV 24 MEFM

IRREGULARITIES WHICH ARE THE MANUFACTURER'S RESPONSIBILITY

No. Crt.	The component	Irregularities	Possible error signal	Repair mode
1	Minimum pressure sensor	The non-running or the un-conformed running	E1	Replace the minimum pressure sensor.
2	Temperature sensors	Interrupted course or defective sensors Central heating DHW	E3 E4	Renew the course or replace the sensors
3	The gas valve	It doesn't run or it runs defectively	E2	Replace the gas valve
4	The heat exchanger	Defective		Replace the exchanger
5	The expansion vessel	Head losses	E1	Replace the expansion vessel
6	The burning	Burner distortions		Replace the burner
7	Ignition-ionization electrode	Parasit flame	E7	Replace the ignition-ionization electrode
8	The control board (switch)	You can't operate the wanted setting any more by pressing. There is no information displayed.		Renew the course. Replace the panel
9	The electronic board	E0 error signal keeps signalling Any irregular running due to the electronic board		Replace the board
10	The spark changer	Defective changer		Replace the changer.
11	Ignition/ ionization electrode	There is no spark between the electrode and the burner or it loses the spark due to the defective isolation or there is no flame.	E2	Setting the distance. Replace the electrode
12	Overheating thermostat	Defective		Replace the overheating thermostat
13	The fan	Defective	E5	Replace the fan.
14	The air pressure switch	Defective	E5	Replace the air pressure switch

IRREGULARITIES WHICH ARE THE SUPPLIER'S RESPONSIBILITY

No. Cr.	The component	Causes	The disturbed system	Possible error signal	Repair mode
1	The boiler doesn't run, there is no signal on display	- electrical power supply deficiency (inadequate electrical circuit, blown safety fuse)	Electrical circuit		Call the electric power supplier
2	The boiler runs intermittently . Damage, noises or vibrations	gas deficiency or unadjusted inlet pressure into the boiler or unadjusted outlet pressure (burner)	Gas supply circuit	E2	Call the gas supplier.
3	The running with unsteady temperature on domestic water	Too low pressure on domestic water (>1bar)	The domestic water circuit		Call the domestic water supplier.

IRREGULARITIES WHICH AREN'T THE PRODUCER'S RESPONSIBILITY

No. Cr.	The component	Causes	Possible error signal	Repair mode
1	The boiler doesn't run, there is no signal on display	Electrical power supply deficiency, inadequate power circuit, blown safety fuse		The user calls the authorized service unit he belongs to.
2	The boiler starts but there is no flame.	The gas valve is closed, the ignition pressure is too low, pressure controller isn't set adequately, there is air in the gas pipe, the pressure is lower than 0,5 bar on the central heating	E2	The user calls the authorized service unit he belongs to.
3	The flame fires up and then it puts out	The reversal of phase with zero	E2	The user calls the authorized service unit he belongs to.
4	The central heating does not heat.	The winter/summer switch is on summer, the boiler was set to run at a too low temperature, the room thermostat is set at a too low temperature, the pipes lay-out is through a below 0° C area and it froze, there is air in installation.		The user calls the authorized service unit he belongs to.

LISTS AND PLANS NECESSARY FOR MOUNTING AND PUTTING INTO SERVICE

Plan 1

The couplings arrangement of Wall hung gas boiler with forced draft

OPTIMUS MT C15 SPV 24 MEFM

THE Coupling	DIMENSION
1. DHW inlet	1/2" - outside thread
2. DHW outlet	1/2" - outside thread
3. Central heating turn	3/4" - outside thread
4. Central heating return	3/4" - outside thread
5. Gas supply	3/4" - outside thread

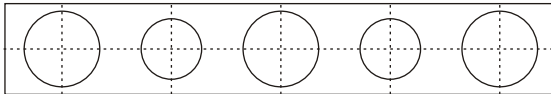

CH turn

3



DHW

2



gas supply

5



cold water

1



CH return

4

Plan 2

Hydraulic diagram of The Wall hung gas boiler with forced draft OPTIMUS MT- C15 SPV 24 MEFM

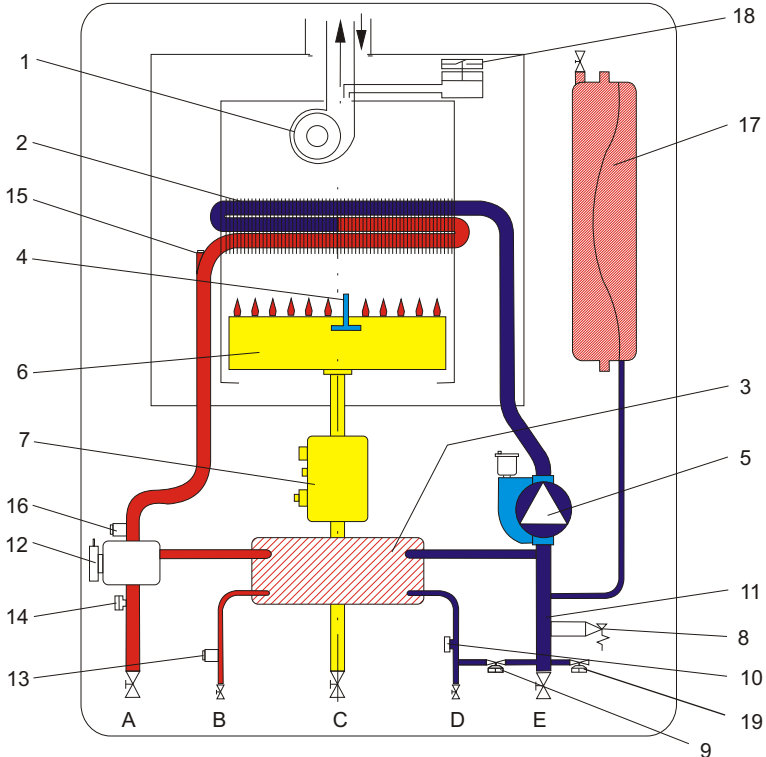

1. Electrical fan with Hall sensor
2. main heat exchanger
3. secondary heat exchanger
4. ignition/ionization electrode
5. electrical pump with exhauster
6. burner
7. gas modulator
8. 3 bar safety valve
9. filling valve
10. flowmeter for the sanitary circuit
11. automatic by-pass
12. 3- way valve

13. temperature sensing probe for DHW
14. minimum water pressure switch
15. safety thermostat
16. temperature sensing probe for heating
17. expansion vessel
18. air pressure switch
19. drain valve

- A. heating turn
 B. DHW outlet
 C. gas inlet
 D. cold water inlet
 E. Heating return

Plan 3

The Couplings diagram for the wall hung gas boiler with forced draft OPTIMUS MT- C15 SPV 24 MEFM

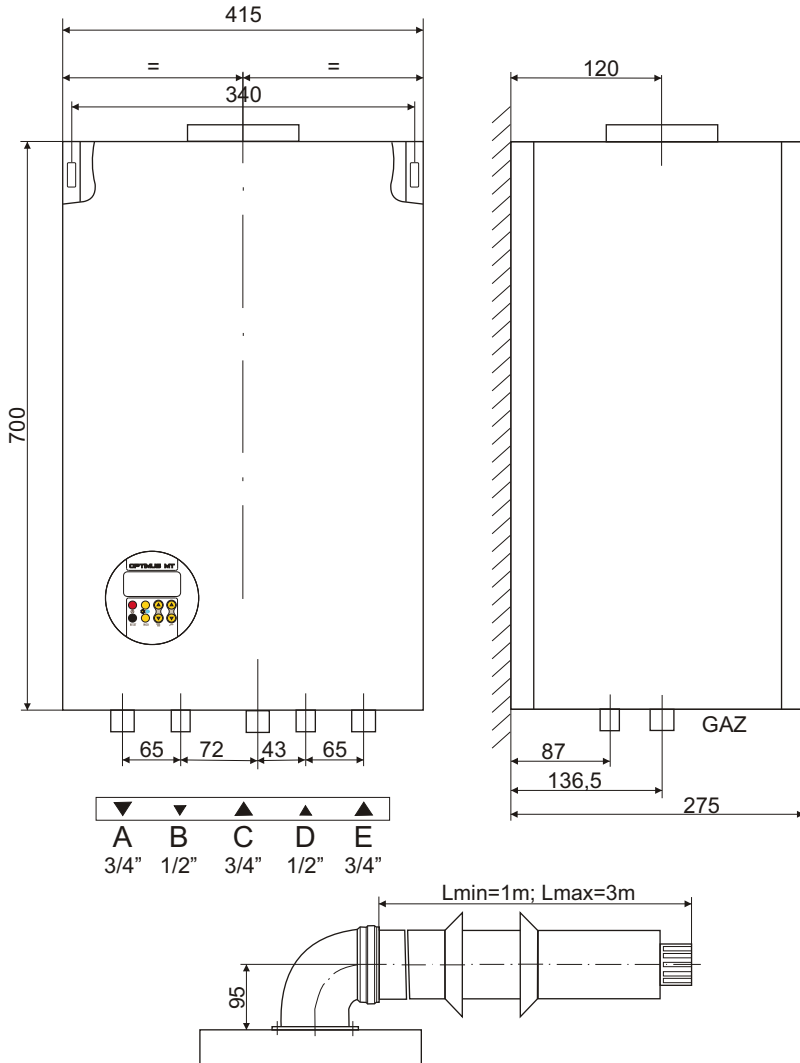

Plan 4

**Typical flue system applications for the
wall hung gas boiler with forced draft
OPTIMUS MT C15 SPV 24 MEFM**

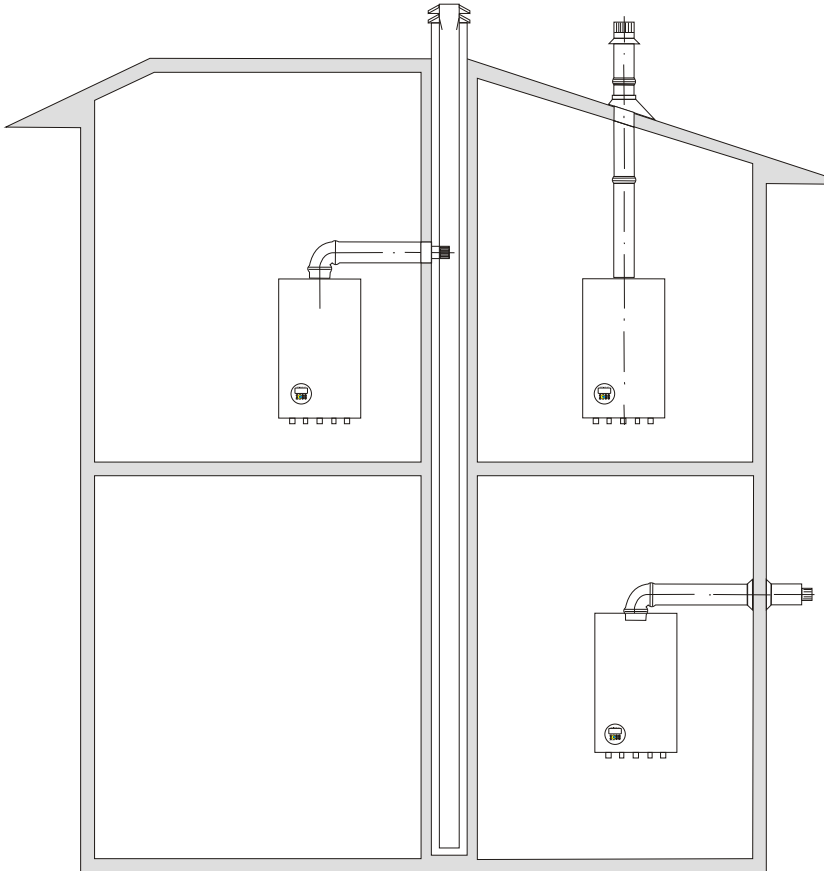

Plan 5

Electrical diagram for the wall hung gas boiler OPTIMUS MT- C15 SPV MEFM

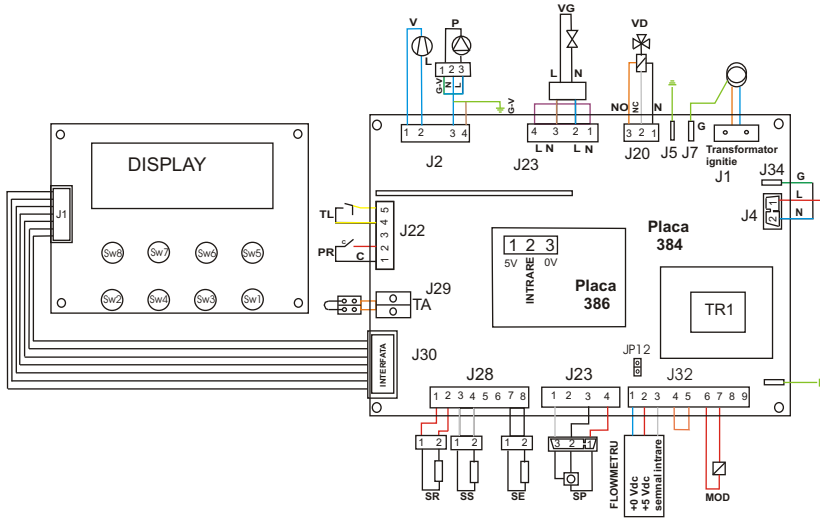

L-supply phase
N-null supply
G-earthing
P-the pump
U2-safety module
TL-overheating thermostat
FLOWMETER-flow sensor

SR- CH temperature sensor
SS- DW temperature sensor
SE-exterior temperature sensor
SP-pressure sensor
TA-room thermostat
PR-air pressure switch
MOD-modulator

TR-ignition transformer
T- zero protection
VG-gas valve
V-fan modulation
TR1-transformer 230/24V
VD-3 -way valve

CONTENTS

General presentation of the wall hung gas boiler.....	pg. 3
General description of the wall hung gas boiler.....	pg 3
Description of the boilers types.....	pg 3
Symbols	pg 3
General instructions concerning the safety of the wall hung gas boiler.....	pg 4
Technical characteristics.....	pg 5
Functional and constructive characteristics	pg 5
Constitutive elements of wall hung gas boiler	pg 6
The heat generator	pg 6
The exhaust gases/water heat exchanger.....	pg 7
The heating and domestic hot water circuits Hydraulic circuits.....	pg 7
The command and control system	pg 8
The external shell	pg 8
The hydraulic characteristic of circulation pump	
Mounting/installation instructions.....	pg 10
The location of the unit	pg10
The central heating	pg10
The gas supply	pg 11
The electric power supply	pg 11
Connection for evacuation of the flue gases	pg 12
Instructions for the final user (beneficiary).....	pg 13
Operating instructions	pg 13
The control panel	pg 13
The LCD display board in the user module	pg 13
The LCD display in the user module Operating mode.....	pg 13
The domestic hot water module, The heating module, Antifrost function, Auto-checking and safety functions, The boiler shutting down in safety conditions	pg 14
The pressure checking	pg 15
The functioning of the heating unit	pg 15
Other functions concerning the safety of the boiler.....	pg 15
Additional facilities that may be obtained by.....	pg 15
Handing over to the beneficiary	pg 15
Reccomendations for the yearly checking	pg. 16
Marking, documents, packing, storage, transport, quality and warranty conditions	pg.17
Marking	pg 17
Documents	pg 17
Packing	pg 17
Storage	pg 17
Shipment.....	pg 17
Quality and warranty conditions	pg 17
Responsibilities during the warranty period	pg 18
Malfunctions which refer to the manufacturer's responsibility	pg 18
Malfuncions which refer to the responsibility of the utilities provider	pg 19
Malfunctions for which the manufacturer is not responsible	pg 19
List and plans necessary for mounting and putting into service	pg 20
Plan 1	pg 20
Plan 2	pg 21
Plan 3	pg 22
Plan 4	pg 23
Plan 5	pg 24